

**HiFi ENGINE®**

For more Hi-Fi manuals and set-up information  
please visit [www.hifiengine.com](http://www.hifiengine.com)

# STEREO POWER AMPLIFIER

# M-70

## SERVICE MANUAL

### FRONT PANEL

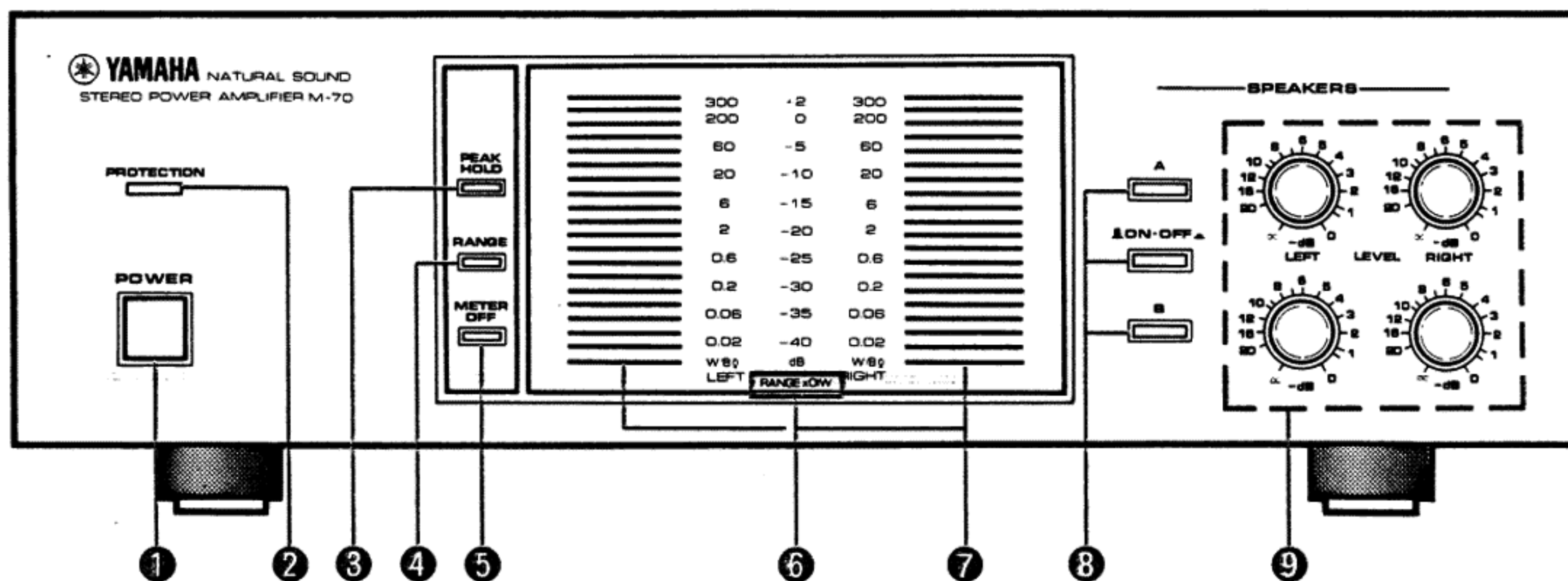

- ① POWER SWITCH
- ② PROTECTION INDICATOR
- ③ PEAK HOLD SWITCH
- ④ RANGE SELECTION SWITCH
- ⑤ METER OFF SWITCH
- ⑥ RANGE INDICATOR
- ⑦ PEAK POWER INDICATORS
- ⑧ SPEAKER SELECTION SWITCHES
- ⑨ SPEAKER LEVEL CONTROL

### CONTENTS

REAR PANELS .....	1
SPECIFICATIONS .....	2
INTERNAL VIEW .....	3
DISASSEMBLY PROCEDURES .....	3
ADJUSTMENT .....	6
CONTROL C. BOARD/SCHEMATIC DIAGRAM (General model) .....	9
CONTROL C. BOARD/SCHEMATIC DIAGRAM (British, Australian and European models) .....	10
BLOCK DIAGRAM .....	11
PRINTED CIRCUIT BOARD .....	12
WIRING DIAGRAM .....	13
SCHEMATIC DIAGRAM .....	14

# REAR PANELS

## ▼ U.S. & CANADIAN MODELS

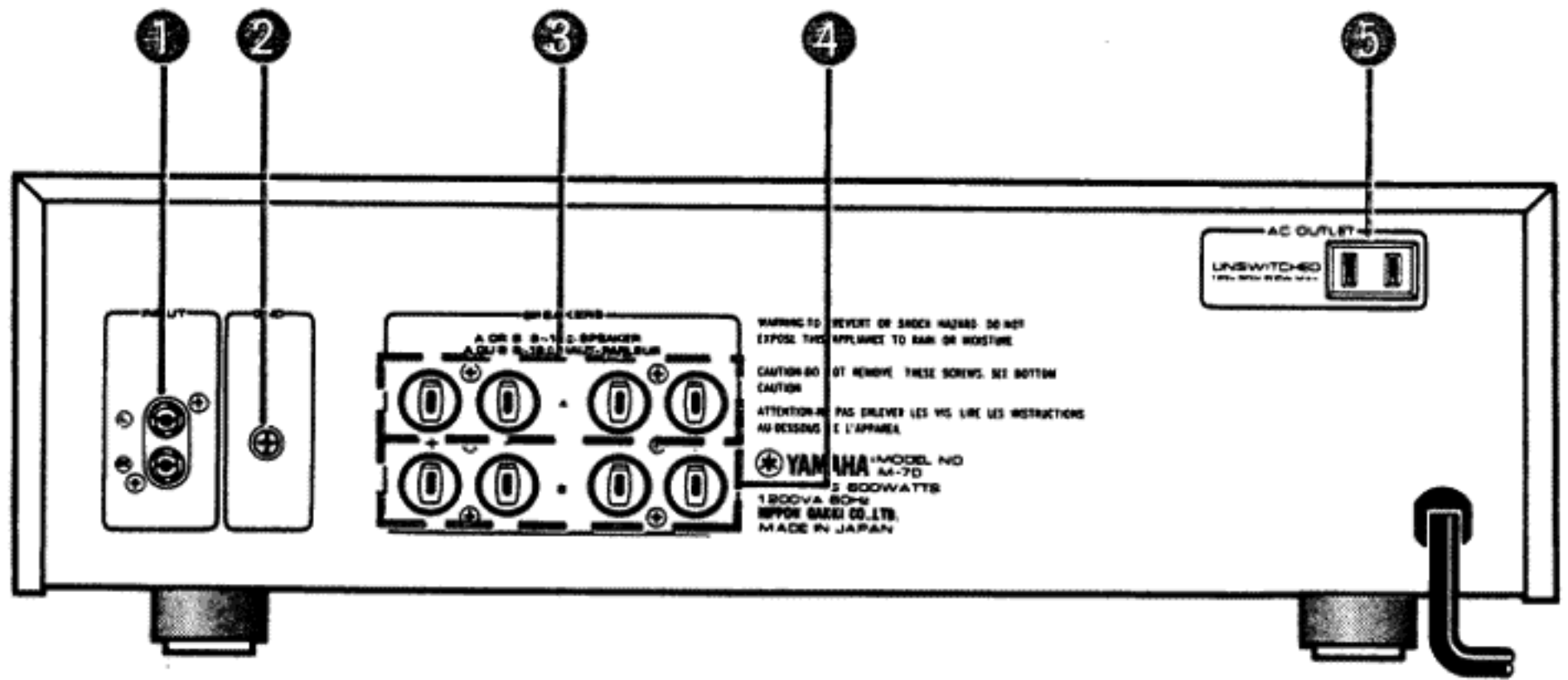

## ▼ GENERAL MODEL

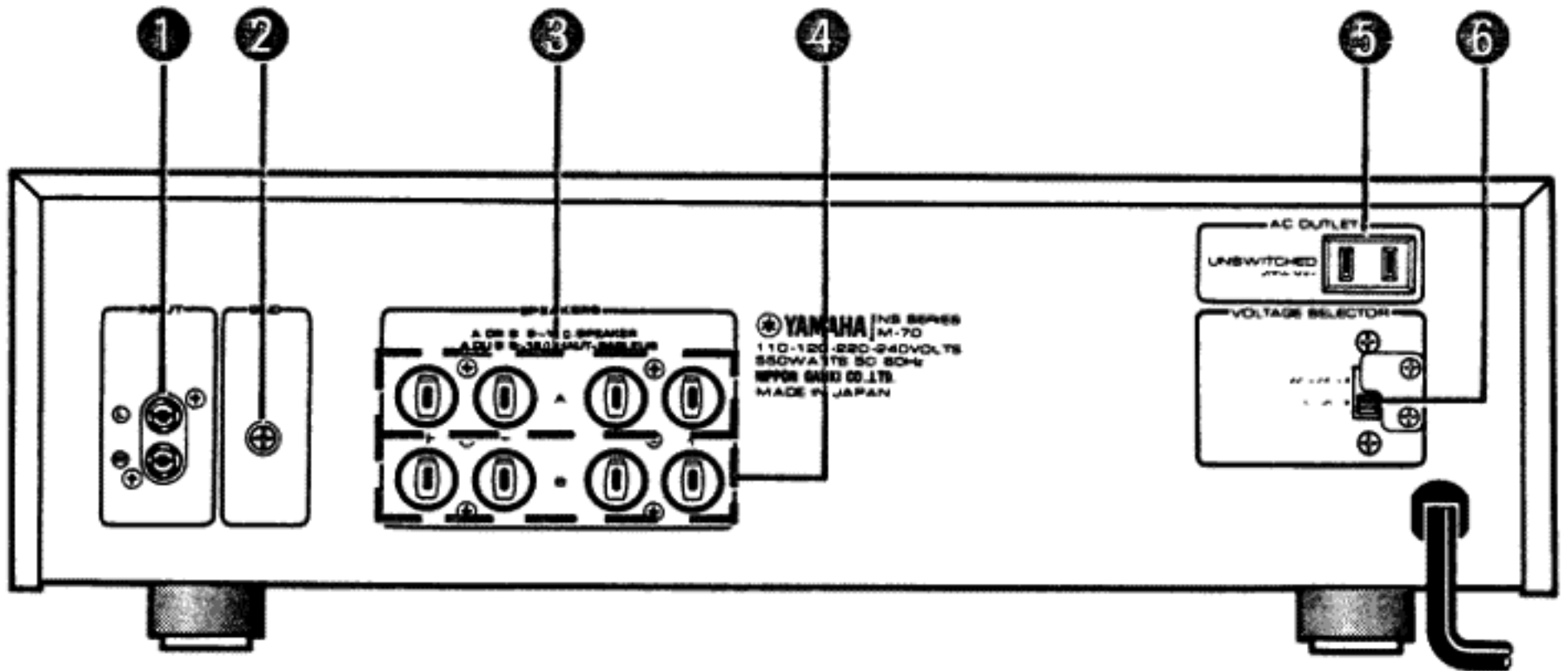

## ▼ BRITISH & AUSTRALIAN MODELS

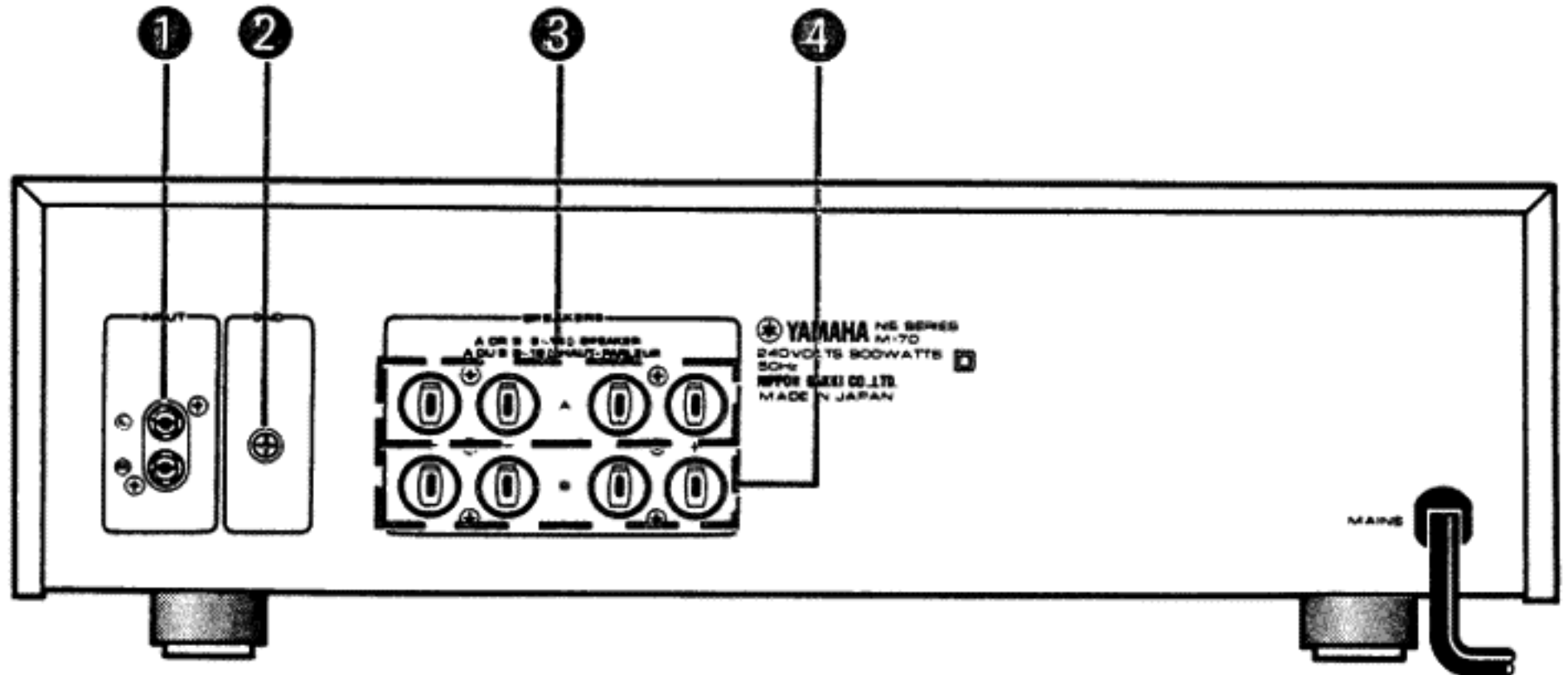

## ▼ EUROPEAN MODEL

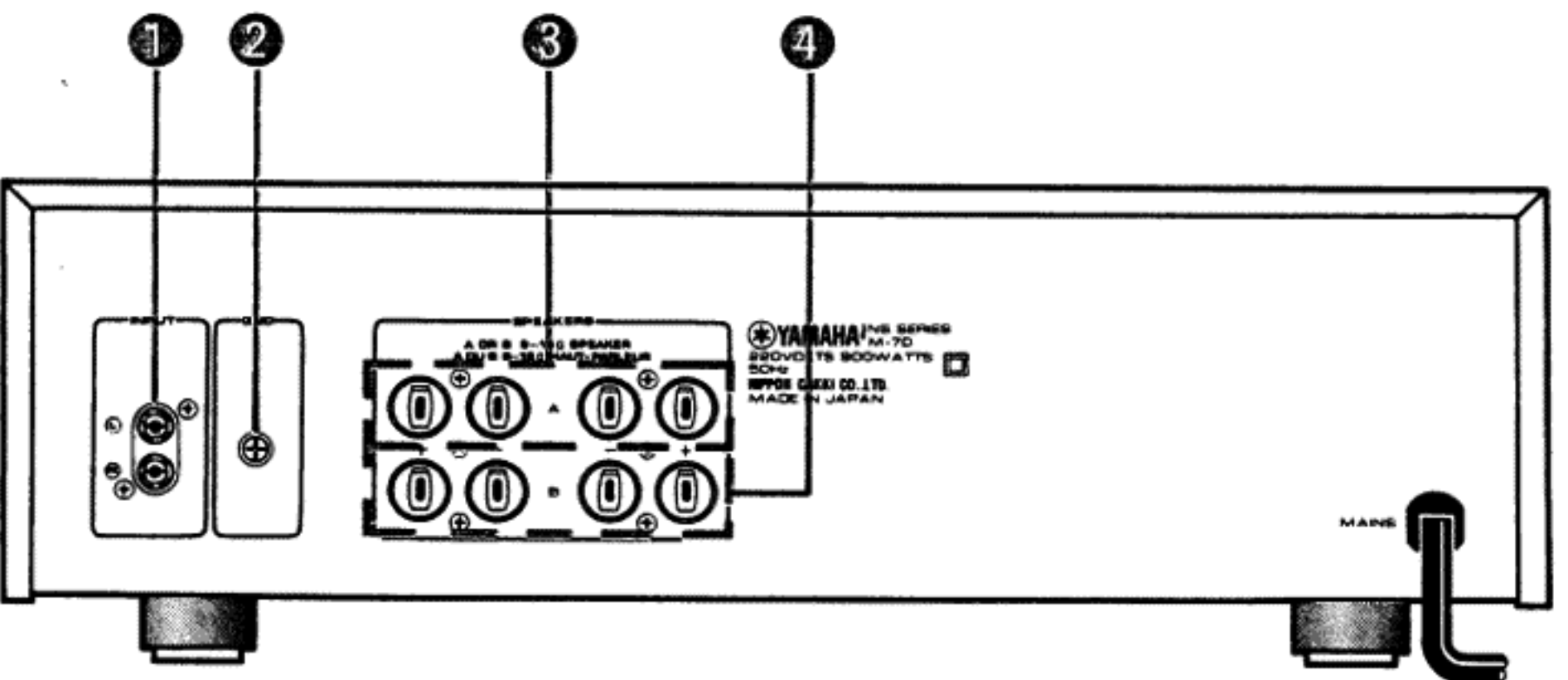

- ① INPUT TERMINAL
- ② GND TERMINAL
- ③ SPEAKER TERMINAL A
- ④ SPEAKER TERMINAL B

- ⑤ AC OUTLET
- ⑥ VOLTAGE SELECTOR

## ■ SPECIFICATIONS

<b>Minimum RMS Output Power</b>	
(8Ω, 20Hz ~ 20kHz, T.H.D. 0.002%)	<b>200W + 200W</b>
<b>4Ω Clipping Power</b>	<b>250W + 250W</b>
<b>Total Harmonic Distortion</b>	
(8Ω, 100W + 100W)	
20Hz	<b>0.0005%</b>
1kHz	<b>0.0005%</b>
20kHz	<b>0.001%</b>
50kHz	<b>0.003%</b>
100kHz	<b>0.006%</b>
<b>IM Distortion Ratio</b>	
(8Ω, 100W)	
50Hz : 7kHz = 4 : 1	<b>0.002%</b>
<b>Power Bandwidth</b>	
(8Ω, 1/2 rated power)	
0.006% THD	<b>10Hz ~ -100kHz</b>
<b>Damping Factor</b>	
(8Ω, 1kHz)	<b>200</b>
<b>Frequency Response</b>	
(8Ω)	<b>DC ~ -100kHz, -0.5dB</b>
<b>Input Sensitivity/Impedance</b>	
(8Ω, 200W, 1kHz)	<b>1.41V/25kΩ</b>
<b>Slew Rate</b>	<b>200V/μsec.</b>

<b>Signal-to-Noise Ratio</b>	
(IHF A Network, 8Ω, INPUT shorted)	<b>124dB</b>
<b>Channel Separation (INPUT shorted)</b>	
20Hz	<b>100dB</b>
1kHz	<b>95dB</b>
20kHz	<b>70dB</b>
<b>Power Supplies</b>	
U.S.A. and Canadian models	<b>AC120V, 60Hz</b>
European model	<b>AC 220V, 50Hz</b>
British and Australian models	<b>AC 240V 50Hz</b>
General model	<b>AC110/120/220/240V 50/60Hz</b>
<b>Power Consumption</b>	
U.S.A. and Canadian models	<b>600W/1200VA</b>
European, British and Australian models	<b>900W</b>
General model	<b>550W</b>
<b>Dimensions (W x H x D)</b>	<b>435 x 380 x 133mm (17-1/8x14-15/16x5-1/4)"</b>
<b>Weight</b>	<b>13.7kg (30 lbs, 3 oz)</b>

*Specifications subject to change without notice.*

## INTERNAL VIEW

### TOP VIEW

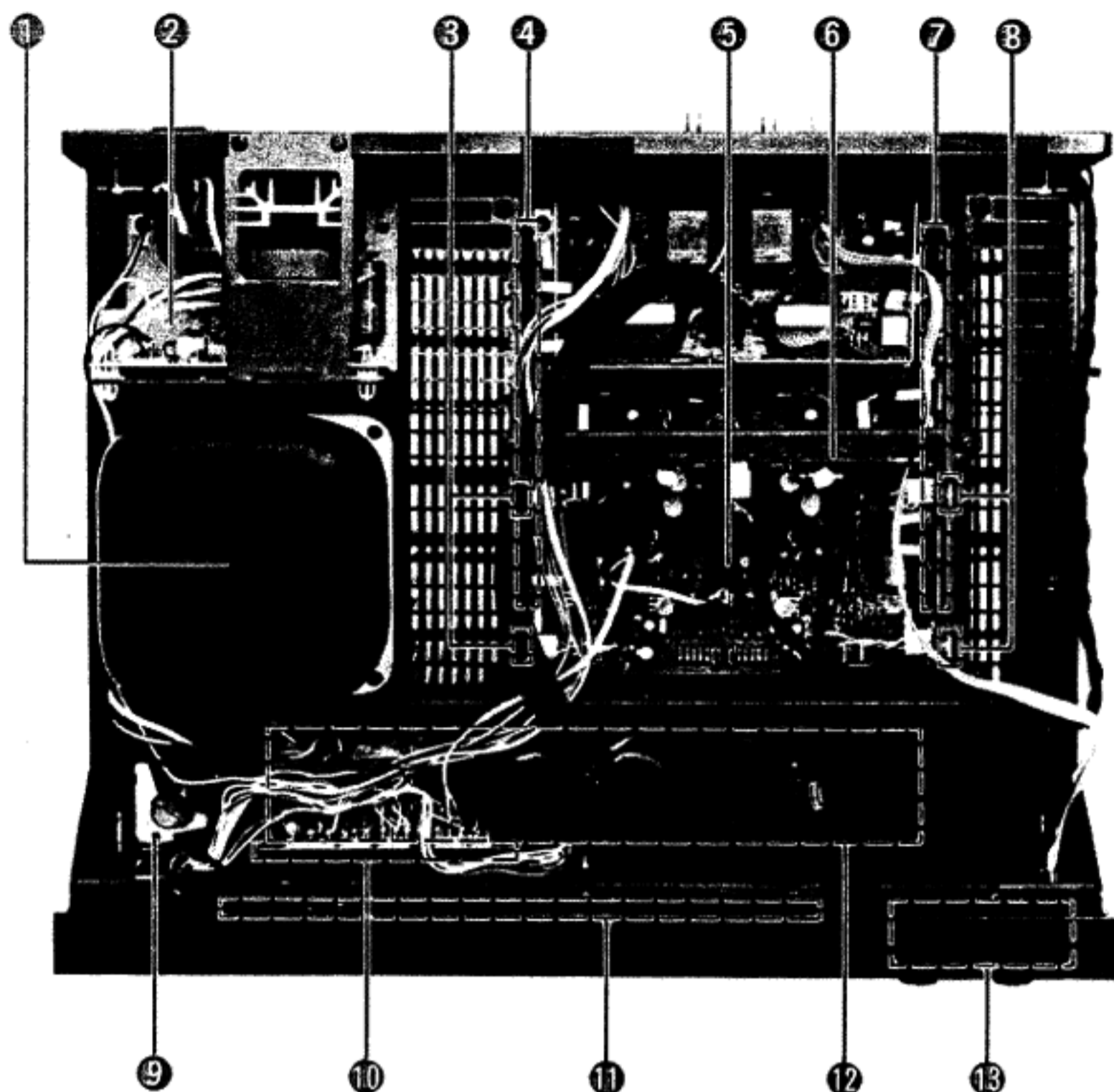

- ① POWER TRANSFORMER
  - U.S.A. model : GA64750
  - Canadian model : GA64760
  - European model : GA64770
  - British & Australian models : GA64790
  - General model : GA64780
- ② CONTROL CIRCUIT BOARD
- ③ DRIVE TRANSISTOR (Lch)
  - 2SA913A (iA09136)
  - 2SC1913A (iC19136)
- ④ POWER TRANSISTOR (Lch)
  - 2SA1146 (iA11460)
  - 2SC2706 (iC27060)
- ⑤ MAIN CIRCUIT BOARD
- ⑥ PREDRIVE CIRCUIT BOARD
- ⑦ POWER TRANSISTOR (Rch)
- ⑧ DRIVE TRANSISTOR (Rch)
- ⑨ POWER SWITCH
- ⑩ POWER CIRCUIT BOARD
- ⑪ METER CIRCUIT BOARD
- ⑫ ELECTROLYTIC CAP, CIRCUIT BOARD
- ⑬ VR CIRCUIT BOARD

## DISASSEMBLY PROCEDURES

### 1. Top cover removal

Remove screws ① and ② from the both left and right sides and screw ③ in Fig. 1. Slide cover away from the front panel, remove the top cover by lifting it.

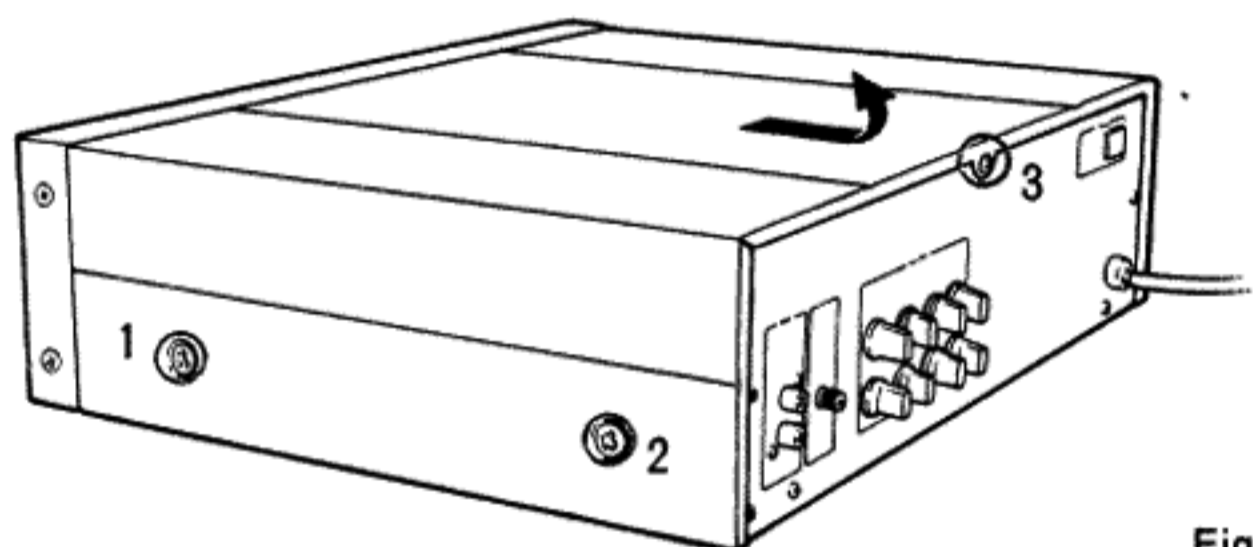

Fig. 1

### 2. Bottom cover removal

Remove screws ① through ⑨ in Fig. 2 and then remove the bottom cover.

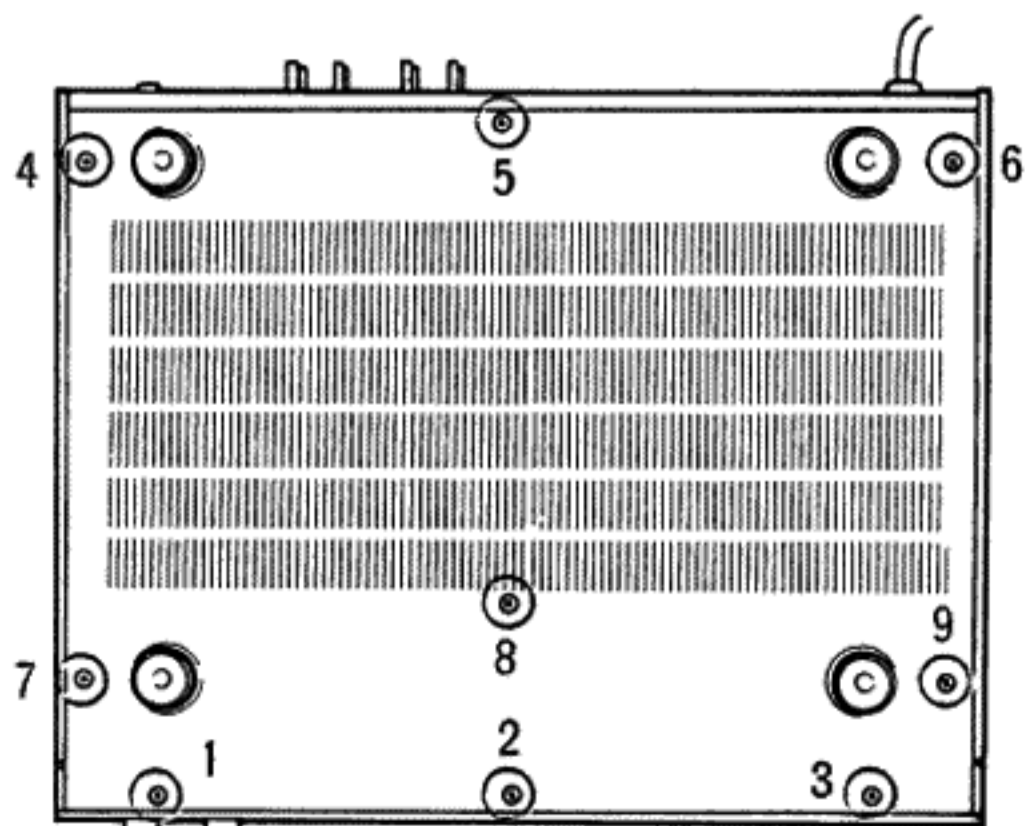

Fig. 2

### 3. Front panel removal

- a. Remove SPEAKER LEVEL knobs.
- b. Remove screws ① through ③ in Fig. 3 and screws ① through ③ in Fig. 2, the front panel may be lifted out forward gently. When is performed, the illumination lamp of the power switch must be disconnected.

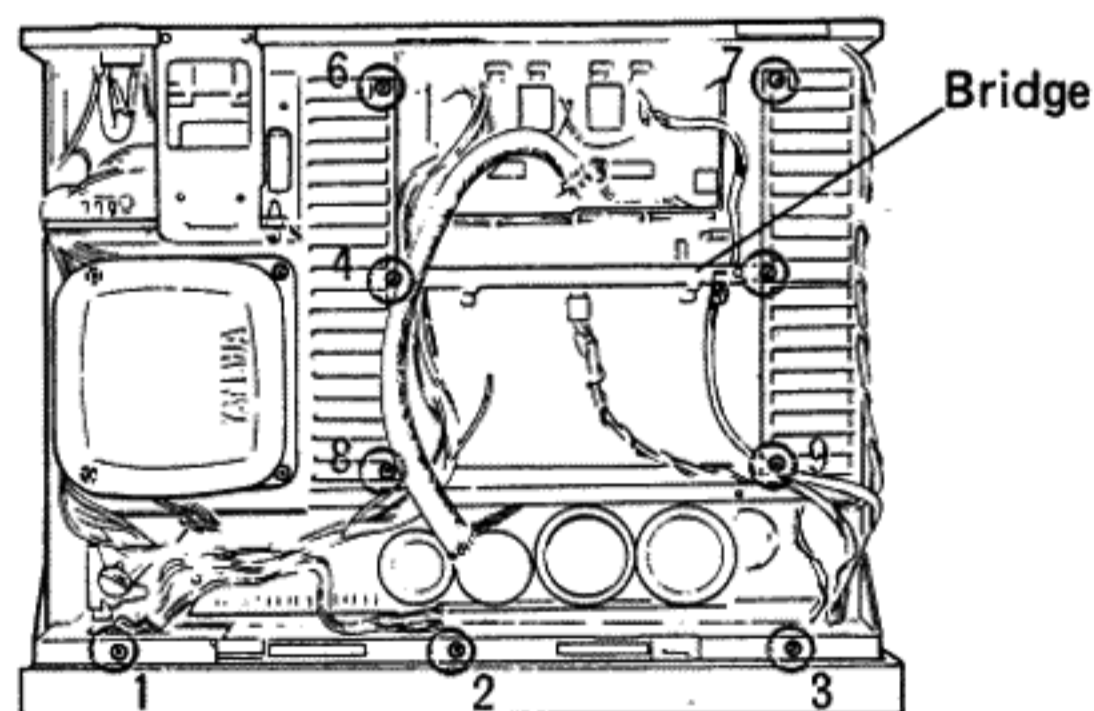
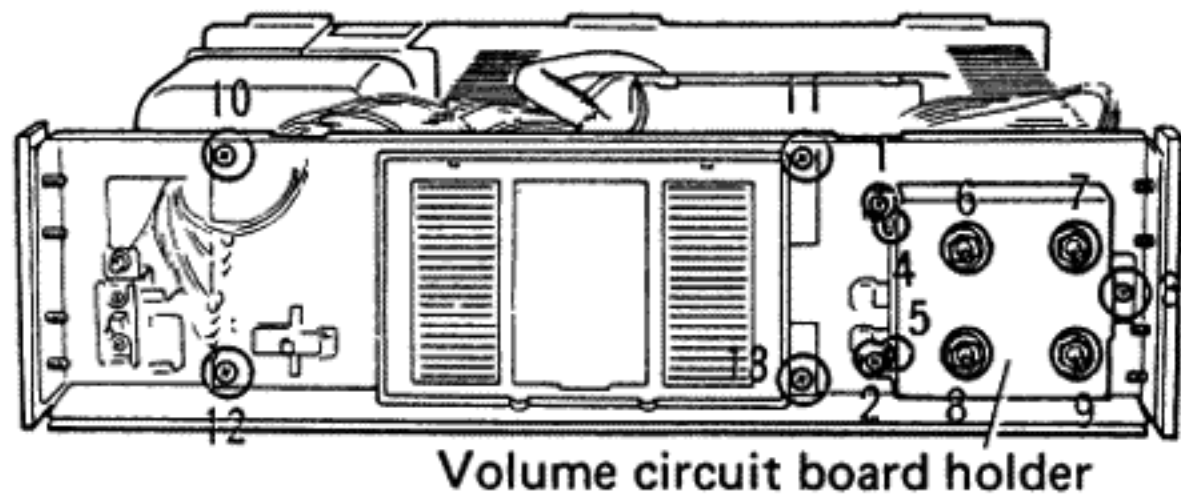

Fig. 3

#### 4. VR circuit board removal

- Remove screws ① through ③ in Fig. 4 and remove the volume circuit board holder.
- Remove screws ④ and ⑤ and hexagonal nut ⑥ through ⑨ in Fig. 4, the VR circuit board may be removed.



Volume circuit board holder

Fig. 4

#### 6. Check of power circuit & replacement of parts

- Remove screws ① and ② in Fig. 7.

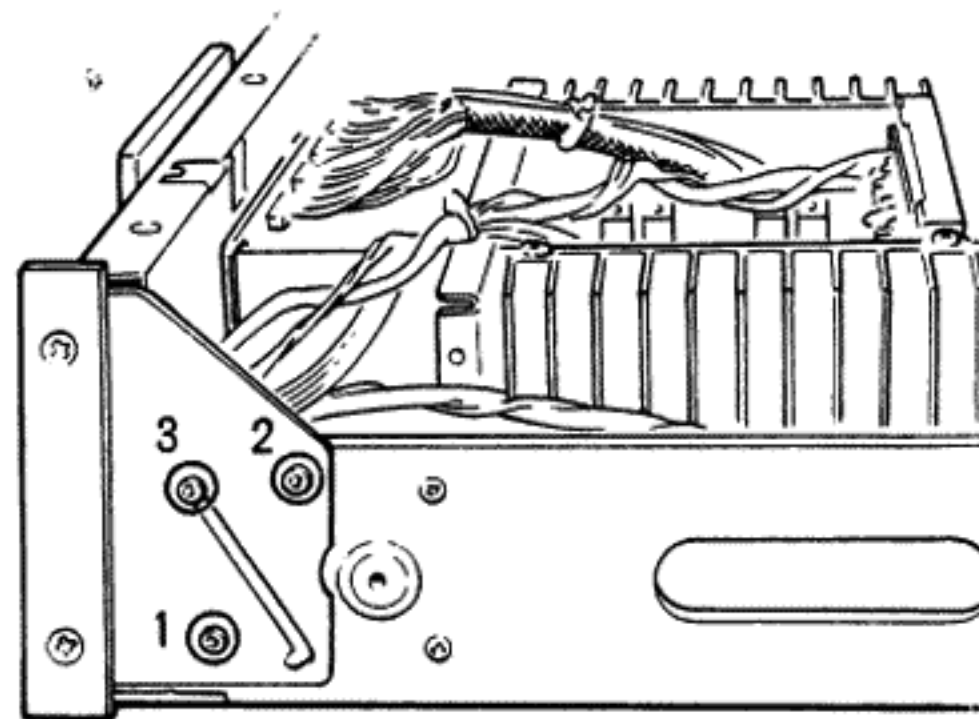

Fig. 7

- Open the sub-chassis as shown in Fig. 8. In this condition it is possible for you to check the power circuit board and to replace the parts.

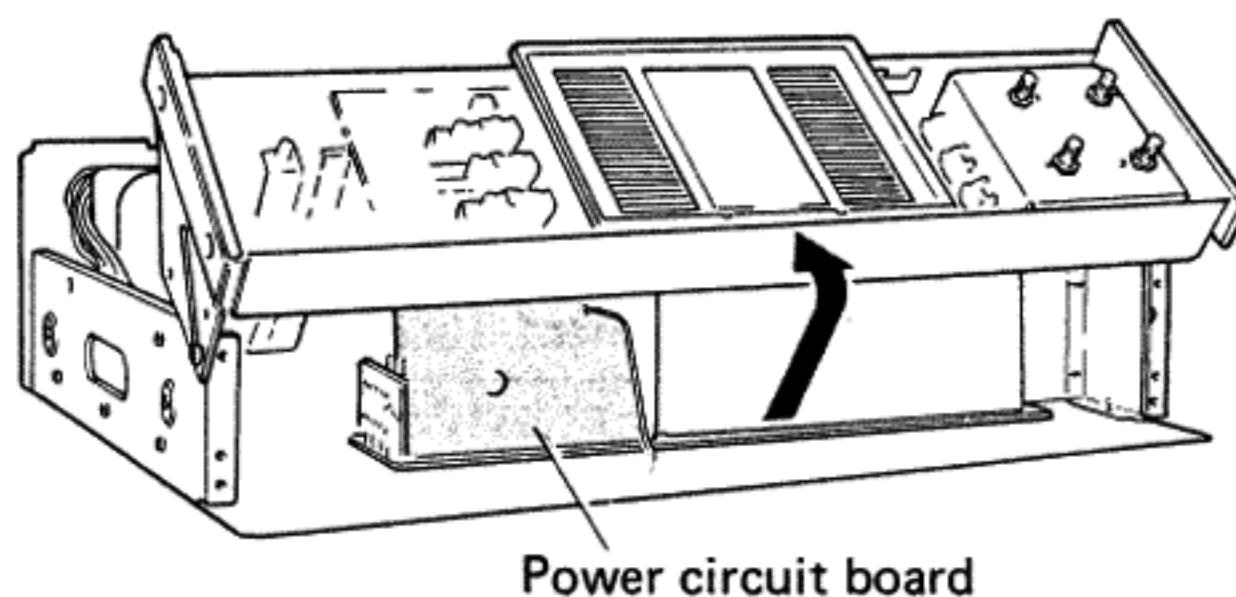

Fig. 8

#### 5. Meter circuit board removal & replacement of parts

- Remove screws ⑩ through ⑬ in Fig. 4 and remove the meter circuit board, and then take off three illumination lamps of the meter circuit board.
- Remove plastic rivets ① through ⑧ in Fig. 5 from the back side of the meter circuit board and remove the meter housing.

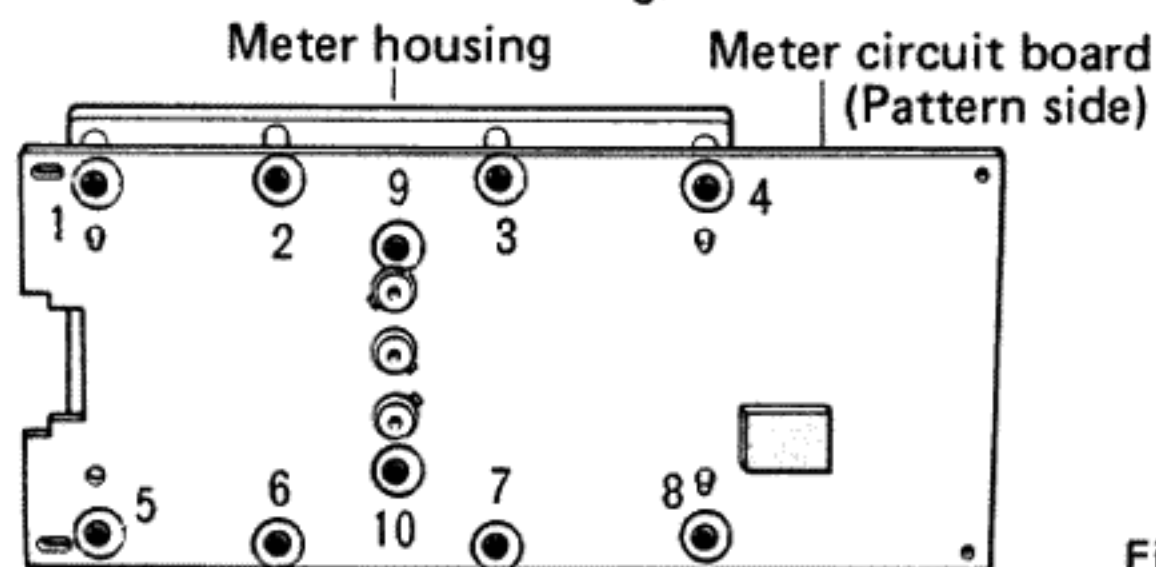

Fig. 5

- Detach one side of the adhesive tape which adheres the meter plate (It is difficult to set on just position if you detach the both left and right sides.) and open the meter plate as shown in Fig. 6.
- Remove plastic rivets ⑨ and ⑩ in Fig. 5 and remove the lamp reflector.
- In this condition it is possible to replace IC503 through 506.

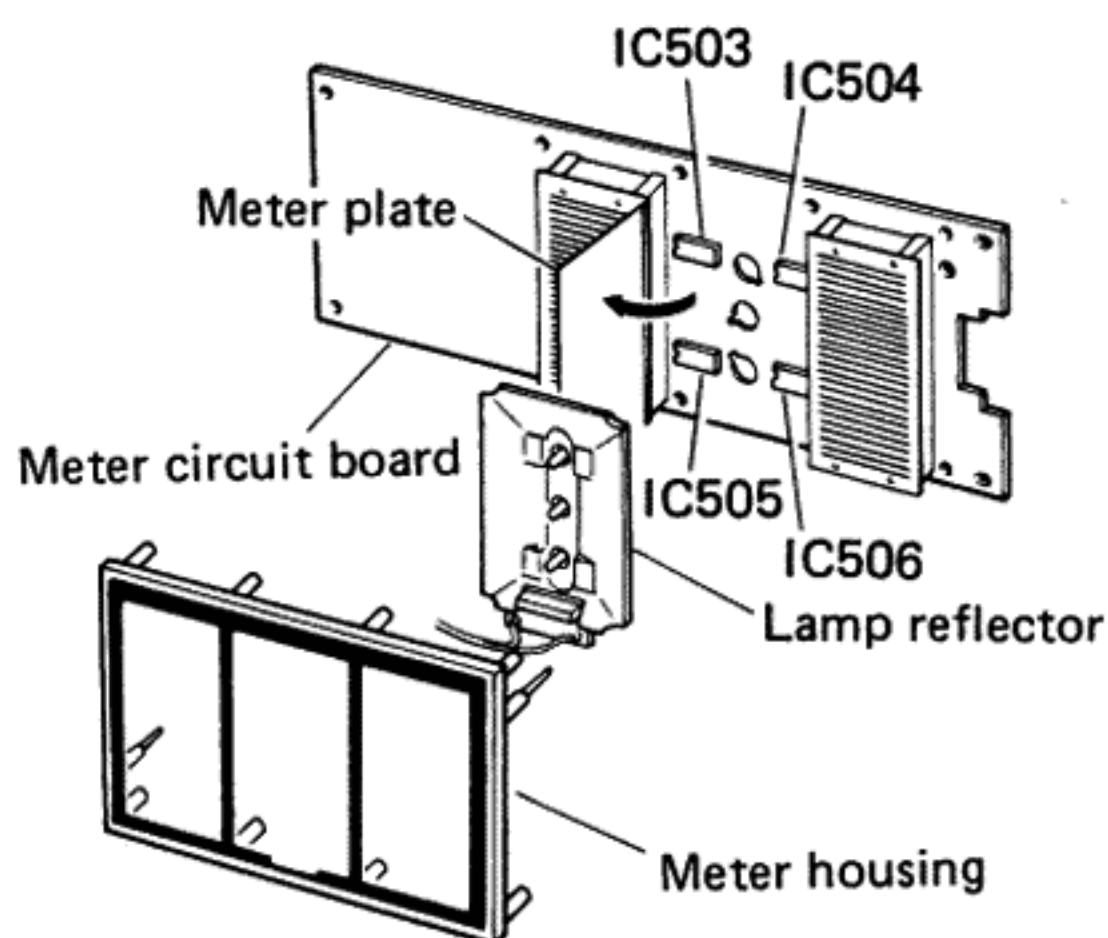

Fig. 6

#### 7. D801, D802 (Electrolytic Cap circuit board) replacement

- Remove screws ① through ③ in Fig. 7 from both left and right sides and remove the sub-chassis.
- Remove screws ① through ⑤ in the inner part of the hole of the power circuit board in Fig. 9, and remove the electrolytic capacitor unit.

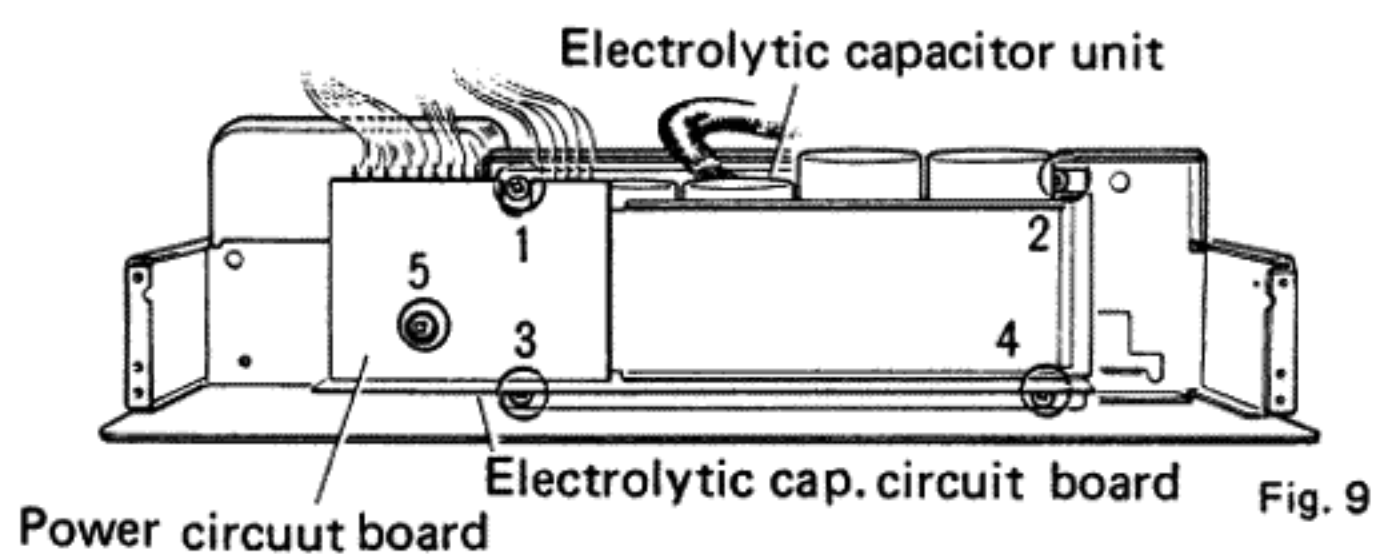

Fig. 9

- Detach the soldering ① through ⑧ of the electrolytic Cap circuit board in Fig. 10, and replace D801 and D802 with heat sink.

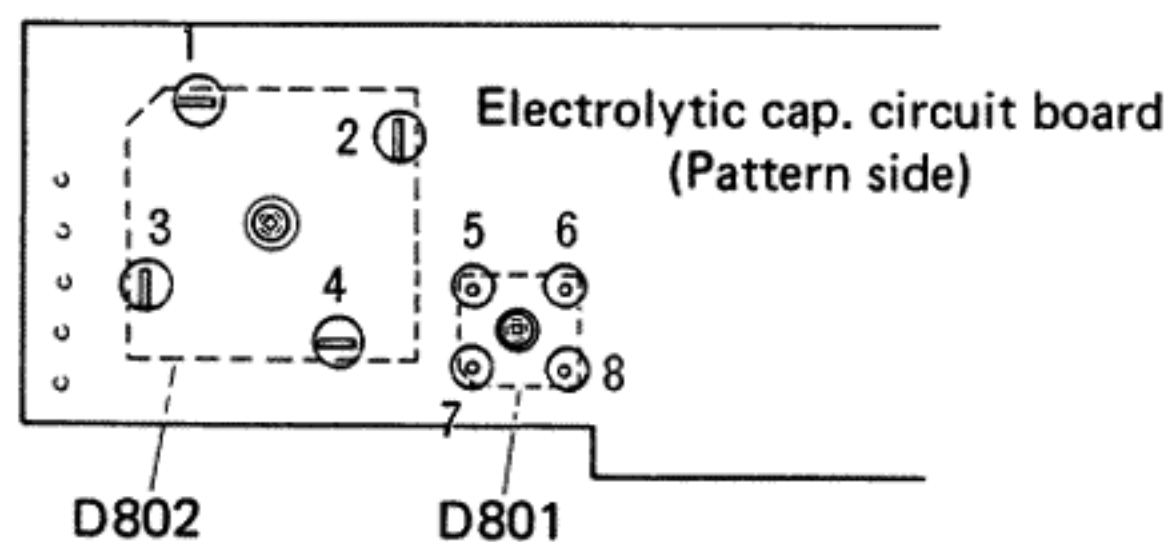

Fig. 10

- d. Remove screws which fix diodes and exchange diodes. When mounting diodes, apply silicon grease to the contact surface of diodes and heat sink. (Fig. 11)

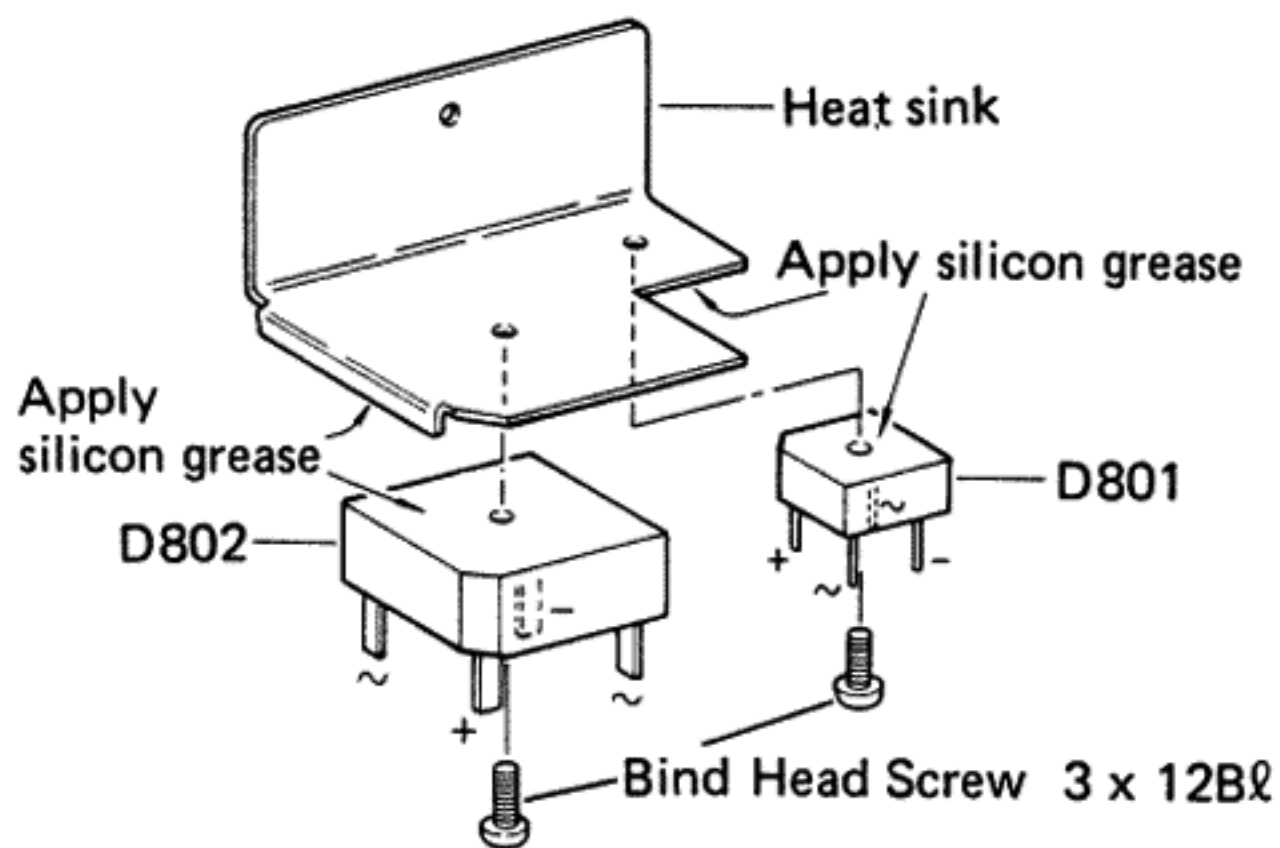

Fig. 11

### 8. Power transistor replacement (Rch)

- Detach the connectors ① and ② in Fig. 12 which are connected to the drive transistors.
- Unsolder the lead wires of the power transistors.
- Remove screws ④ and ⑤ in Fig. 3 and detach the bridge.
- Remove screws ⑦ and ⑨ in Fig. 3 and detach the heat sink.
- Remove screws ③ through ⑩ in Fig. 12 which fix the power transistors and then exchange the transistors.

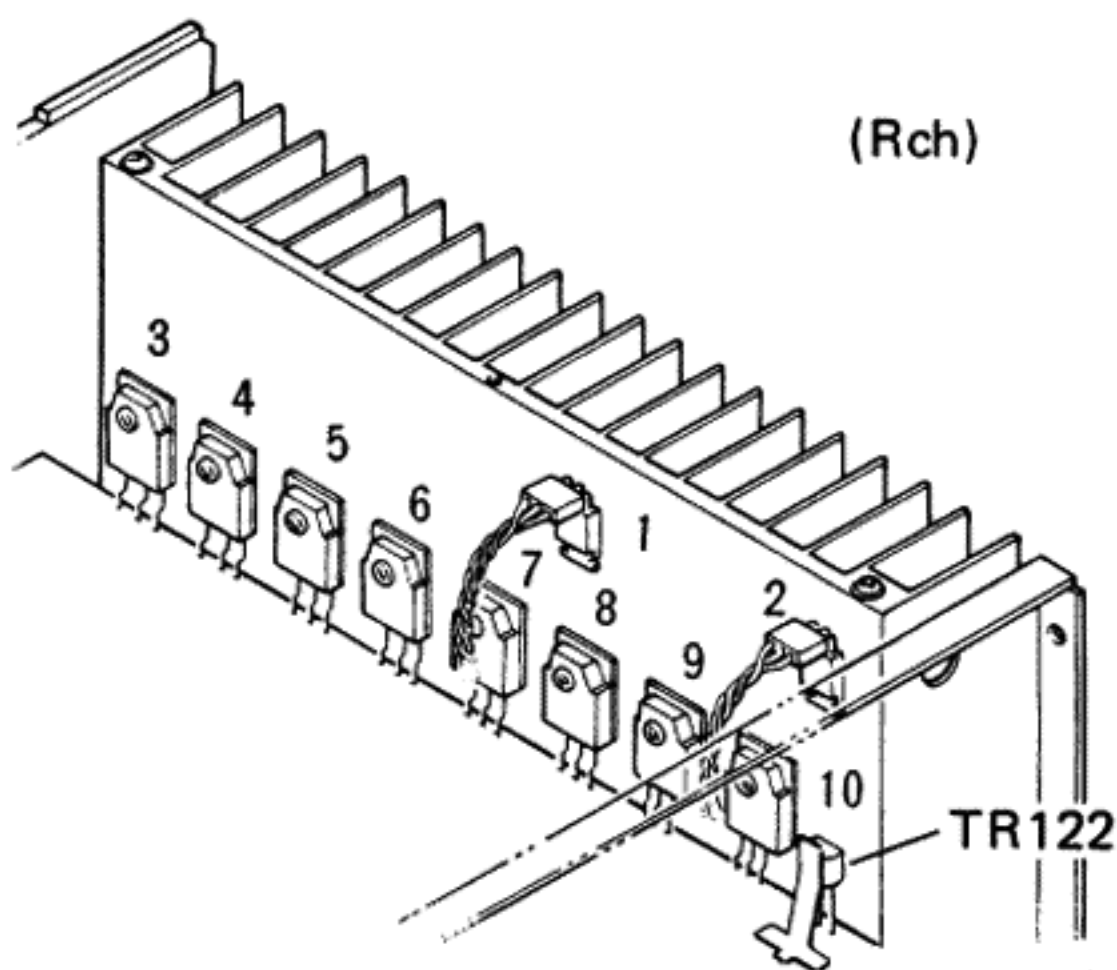

Fig. 12

- \* When mounting the power transistors, install a mica base between the heat sink and transistors so that the heat sink will not touch the case of the power transistor. Apply silicon grease to both sides of the mica base so that heat coupling between power transistors and the heat sink will be efficient. (Fig. 13)

### Mounting TR135 ~ TR150

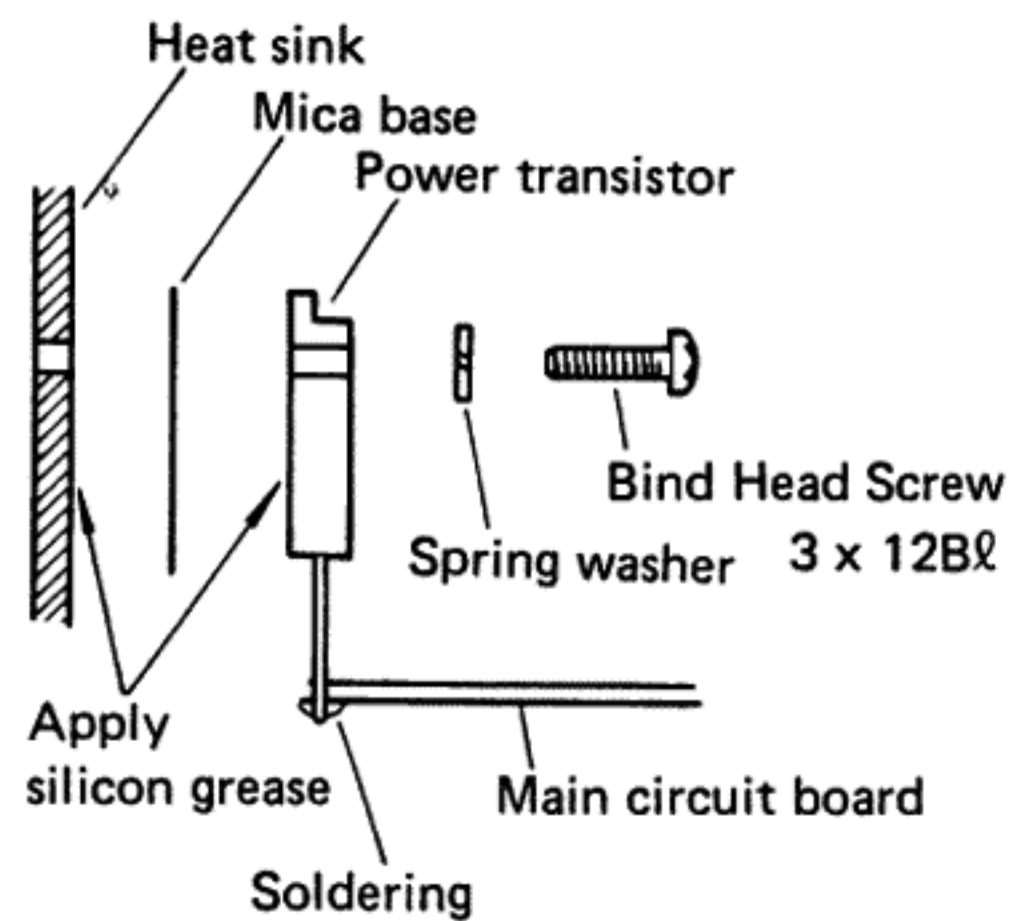

Fig. 13

- Replace the drive transistors as shown in Fig. 13. Use the isolation bushing as shown in Fig. 14 when mounting the drive transistors.
- Mount the heat sink on which power and drive transistors have been secured. After the heat sink is secured with screws ⑦ and ⑨ in Fig. 3, solder the lead wires of power transistors to the main circuit board.
  - \* After the heat sink has been mounted, check that TR122 can sufficiently touch the heat sink. Apply silicon grease to the contact surface. When the heat coupling between power transistor and the heat sink is imperfect, the power transistors may be damaged by thermal run away. (Fig. 12)
- Attach the connector to the drive transistor.
  - \* Be careful about the direction [B(base), C(collector), E(emitter)] of the connector. (Fig. 14)

### Mounting TR131 ~ TR134

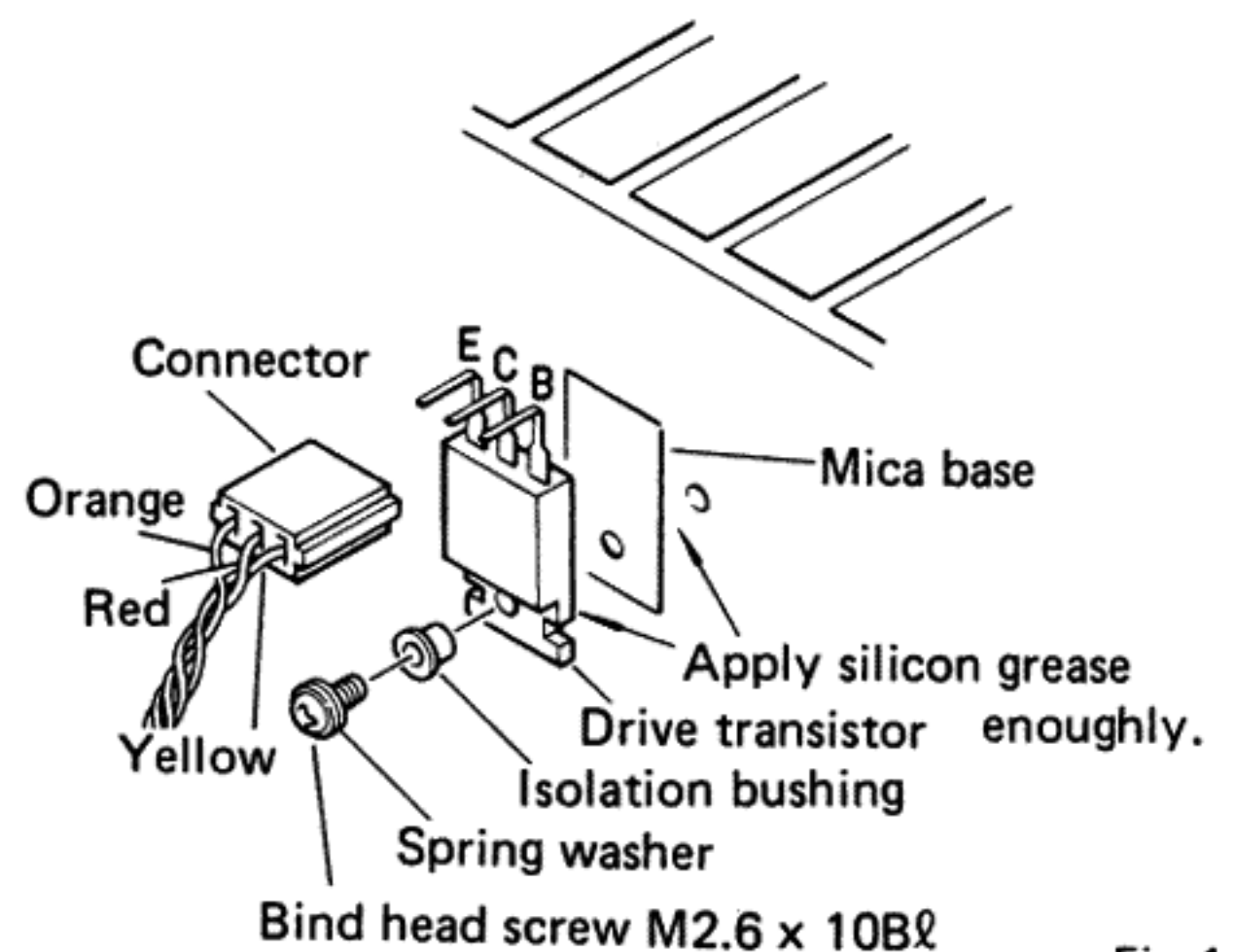

Fig. 14

# ADJUSTMENTS

## BEFORE COMMENCING

1. Make sure that primary supply voltage comes within  $*120V \pm 10%$  (U,C models).
2. Proceed with the adjustments about 5 minutes after the power has been turned on to stabilize the operation of the amplifier.

\* G model 220V  
B, A models 240V

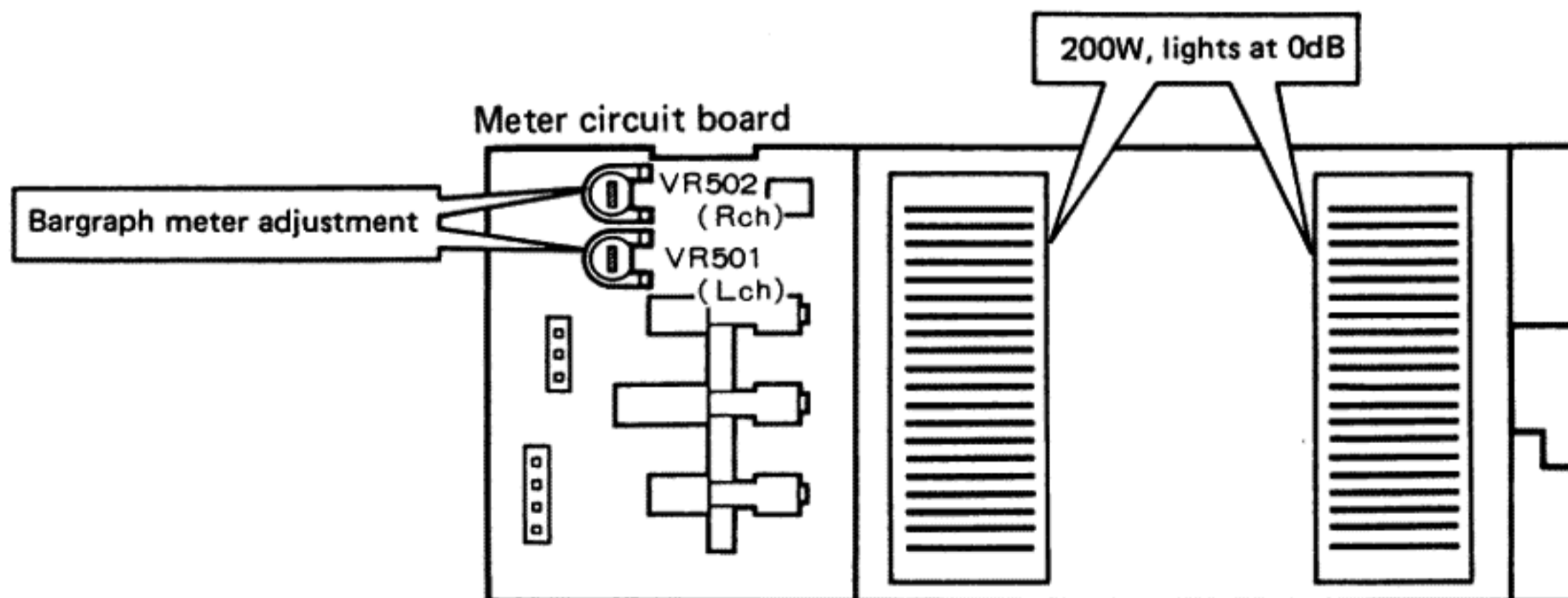
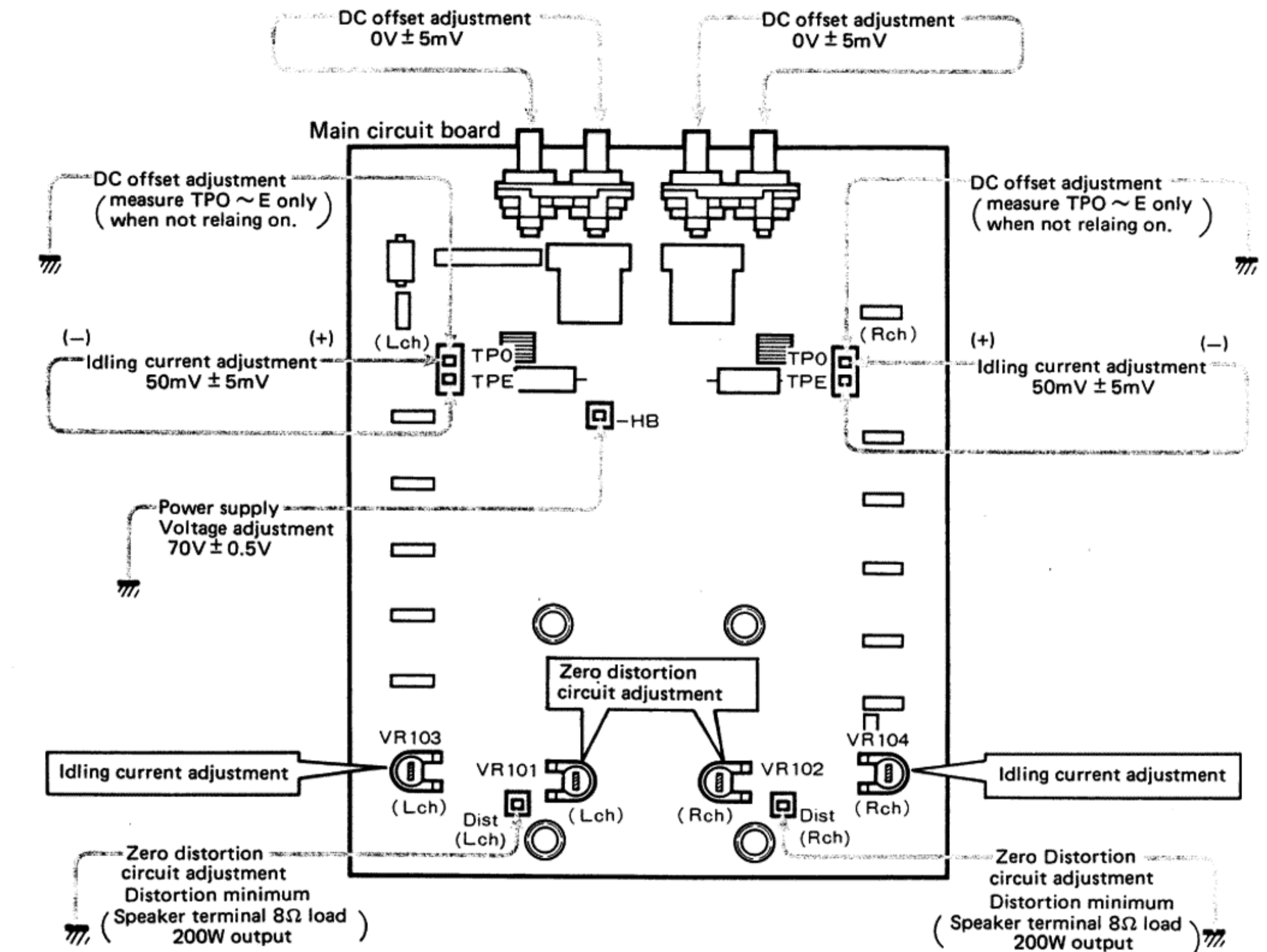



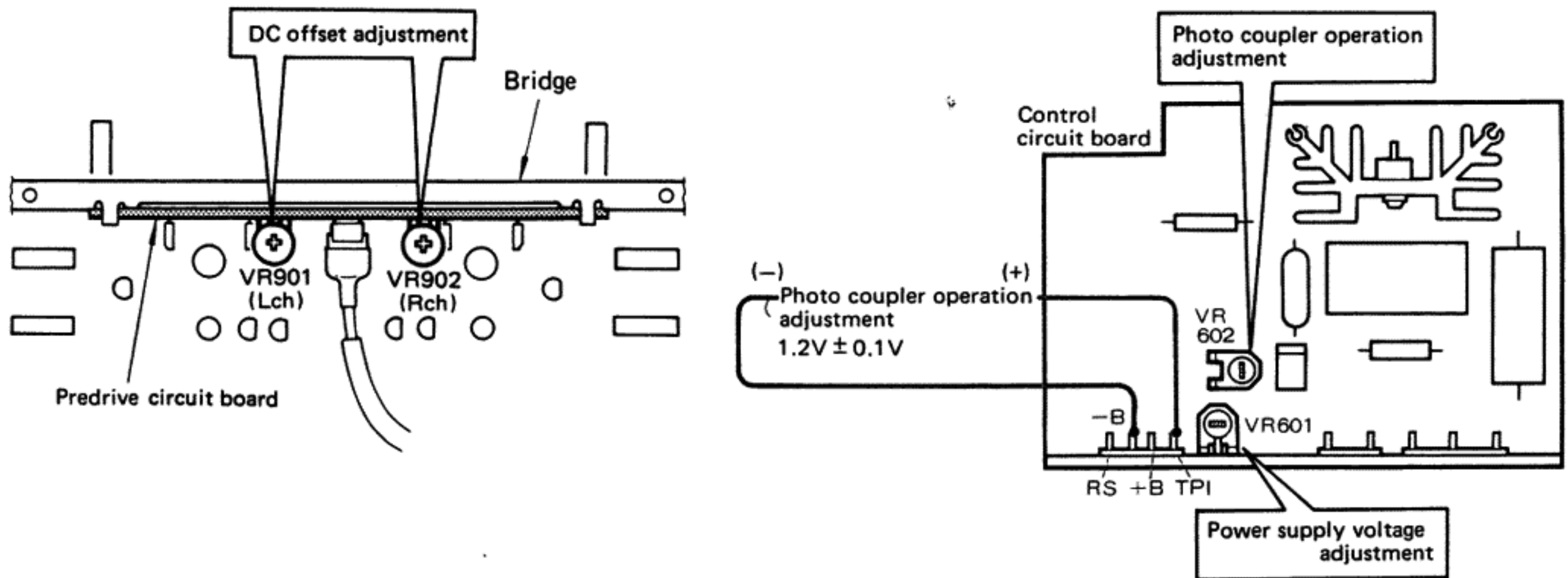

Step	Adjustment	Adjustment points	Test points	Rating	Remarks
1*	-B power supply voltage adjustment	Control circuit board VR601	Main circuit board -HB(-) ~ E(+)	70V ± 0.5V	No load
2*	Photo coupler voltage adjustment	Control circuit board VR602	Control circuit board -B(-) ~ TP1(+)	+1.2V ± 0.1V	No load
3	DC offset adjustment	Pre drive circuit board VR901(L) VR902 (R)	Speaker terminal (TPO(+) ~ TPE(-) only) (when relay not on)	0V ± 5mV	
4	Idling current adjustment	Main circuit board VR103 (L) VR104 (R)	Main circuit board TPO(+) ~ TPE(-)	50mV ± 5mV	No load
5	Bargraph meter adjustment	Meter circuit board VR501 (L) VR502 (R)	Speaker terminal 1kHz 200W (34.2dBm) 8Ω load	Meter point 0dB	0.5dB decreasing, it is lit dimly.
6	Zero distortion circuit adjustment	Main circuit board VR101 (L) VR102 (R)	DIST ~ E (1kHz at SP terminal 8 Ω load, 200W(34.2dBm) output)	After confirming minimum point of distortion, adjust so that the distortion comes minimum	Adjust as shortly as possible with taking notice of the load.

※ Accomplish steps 1\* and 2\* at the same time by using two digital multimeters.

● **Precautions in adjusting the control circuit board**

Note 1) Since the AC mains is connected directly to the control circuit board be particularly careful against electric shock.

Note 2) Always check voltages by measuring the voltage between the reference measuring point and check point.

Note 3) Use floating inputs for wave form measuring purposes. If the oscilloscope body is grounded the measuring circuit will be in danger of being short circuit. In this case, however, do not touch the oscilloscope body by hand since the voltage applied to the oscilloscope could possibly result in an electric shock.

**CHECK POINTS**

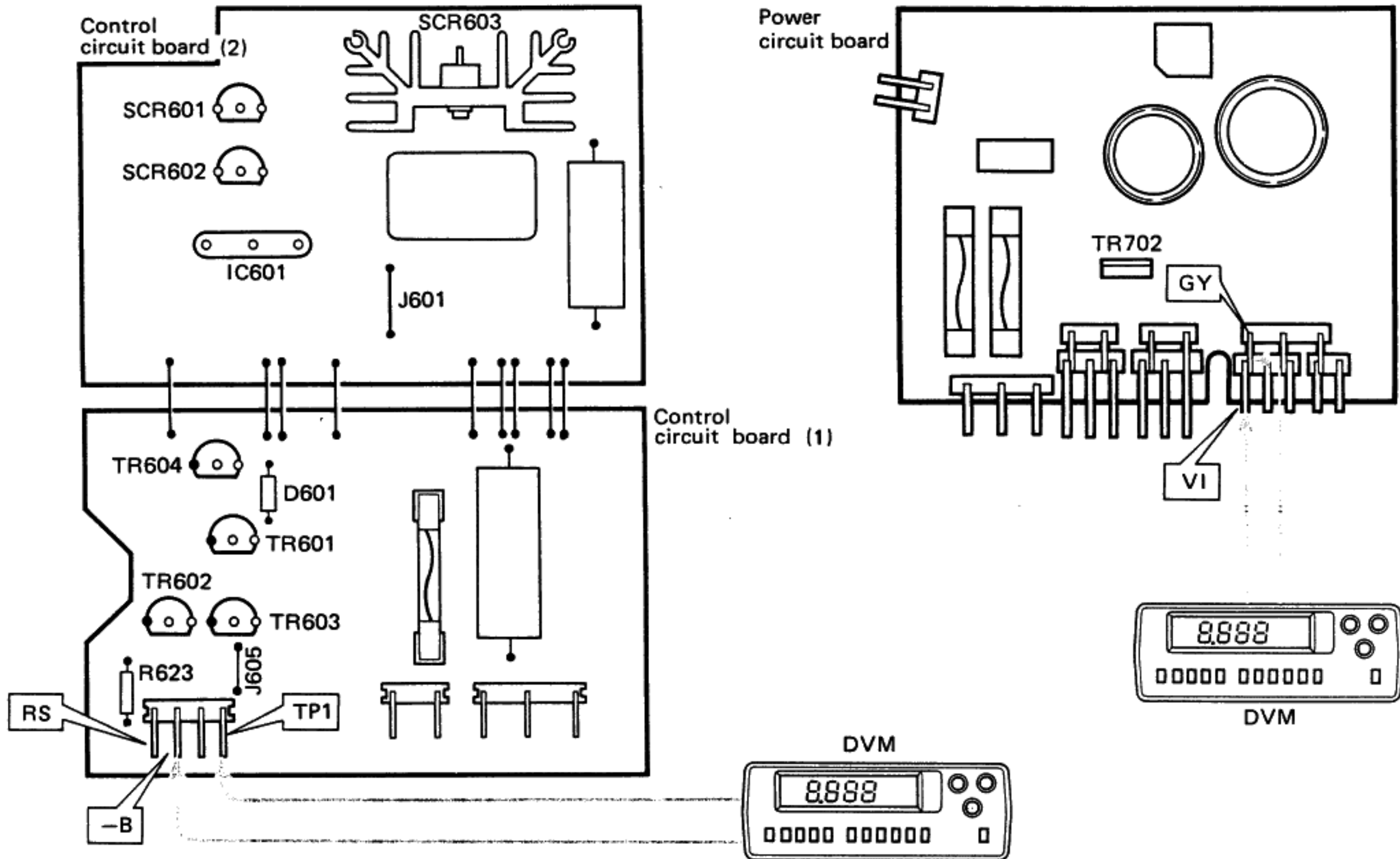

**POWER SUPPLY TROUBLESHOOTING**

■ **To Confirm Proper Operation of Control Circuit Board (1):**

- 1) Short between terminal TP1 and J605 with a jumper on control circuit board (1).
- 2) Connect a DVM across terminals GY and VI on the power supply circuit board.
- 3) Connect the unit to a Variac (Slide Transformer) and adjust mains voltage from 0V to \*120V AC (U.C models) while monitoring the DVM. At 50V AC (U.C models) input to the unit, the DVM should read 0.41V AC and at 120V AC (U.C models) input it will read 5.5V AC/at 220V AC (R.G.B.A. models) input it will read 15.4V AC.
  - A. If the DVM reads 0V AC the most likely problem is an open SCR, Triac, or a short in the amplifier circuitry.
  - B. If the DVM reads the same as (or is proportional to) the AC input voltage, the most likely problem is a shorted SCR, Triac, or Control IC.

■ **To Confirm Proper Operation of Control Circuit Board (2):**

(This should be done only after Circuit (1) has been confirmed to be working properly).

- 1) Connect DVM across R623 and set to DCV. This resistor can be monitored at test point TP1 and -B.
- 2) Adjust the Variac from 50V AC to \*120V AC (U.C models). The DVM should read 1.2V ±0.1V DC at \*120V AC (U.C models)/2.0V ±0.1V at 220V AC (Ⓧ . Ⓧ models only), input to the unit.
  - A. If the voltage across R623 is high (or remains the same) when the Variac is adjusted from 50 to \*120V AC, this indicates a shorted component (check transistors TR601, 602 & 603).
  - B. If there is 0V DC across R623, check the "reset" terminal (marked RS). This point should measure 0V DC for normal operation. If RS is at 0V DC, check TR601, TR604 and D601 first. If RS is not 0V DC, check TR802.

\* R,A,G,B models 220V AC

# CONTROL C. BOARD / SCHEMATIC DIAGRAM (General model)

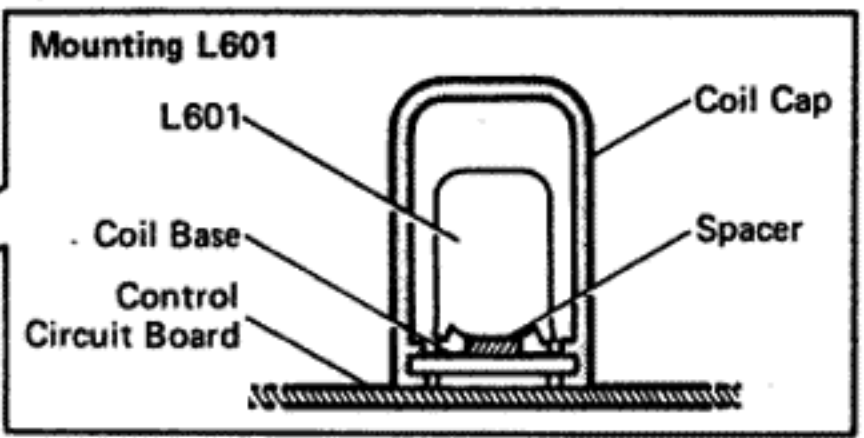
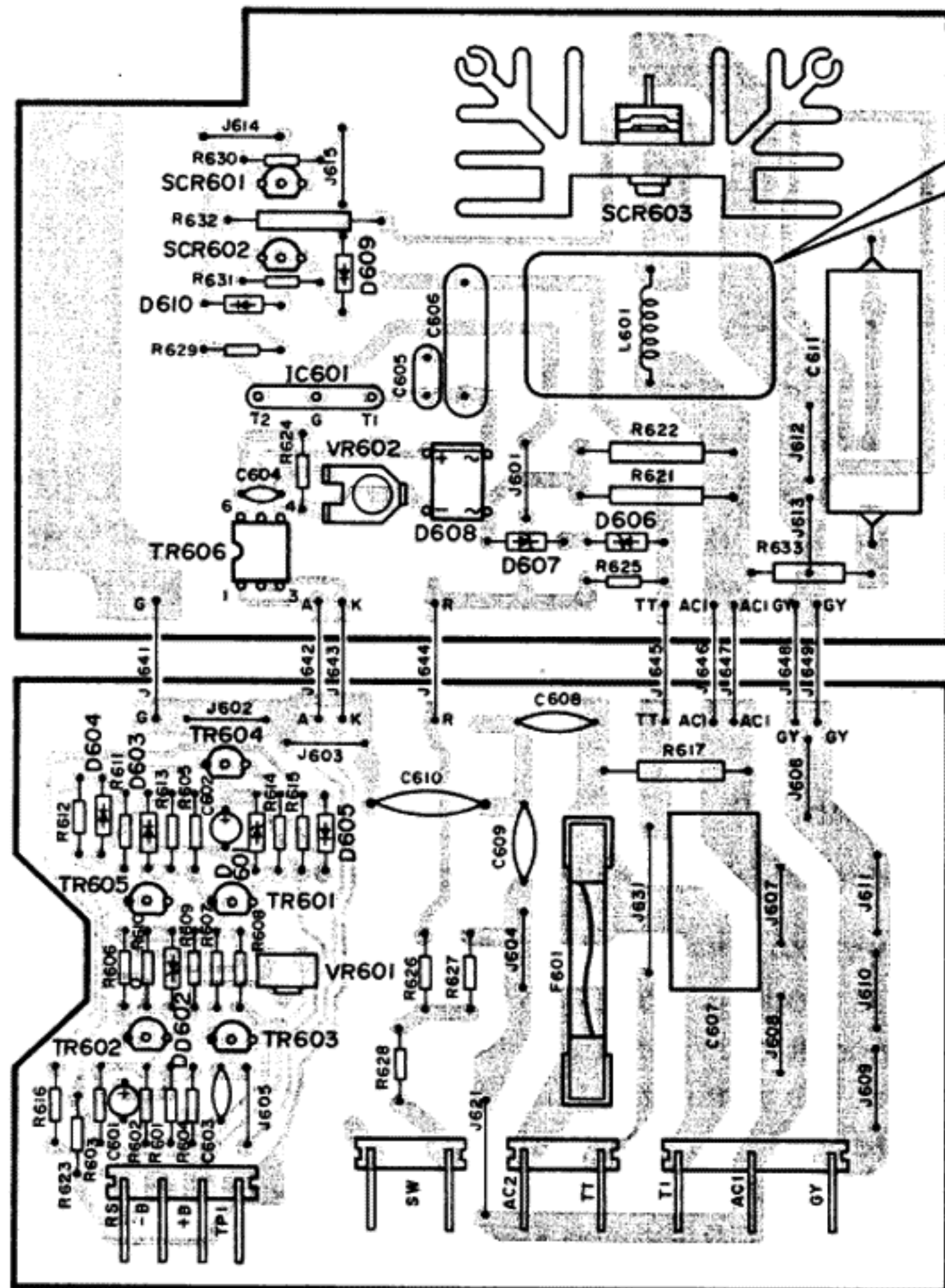
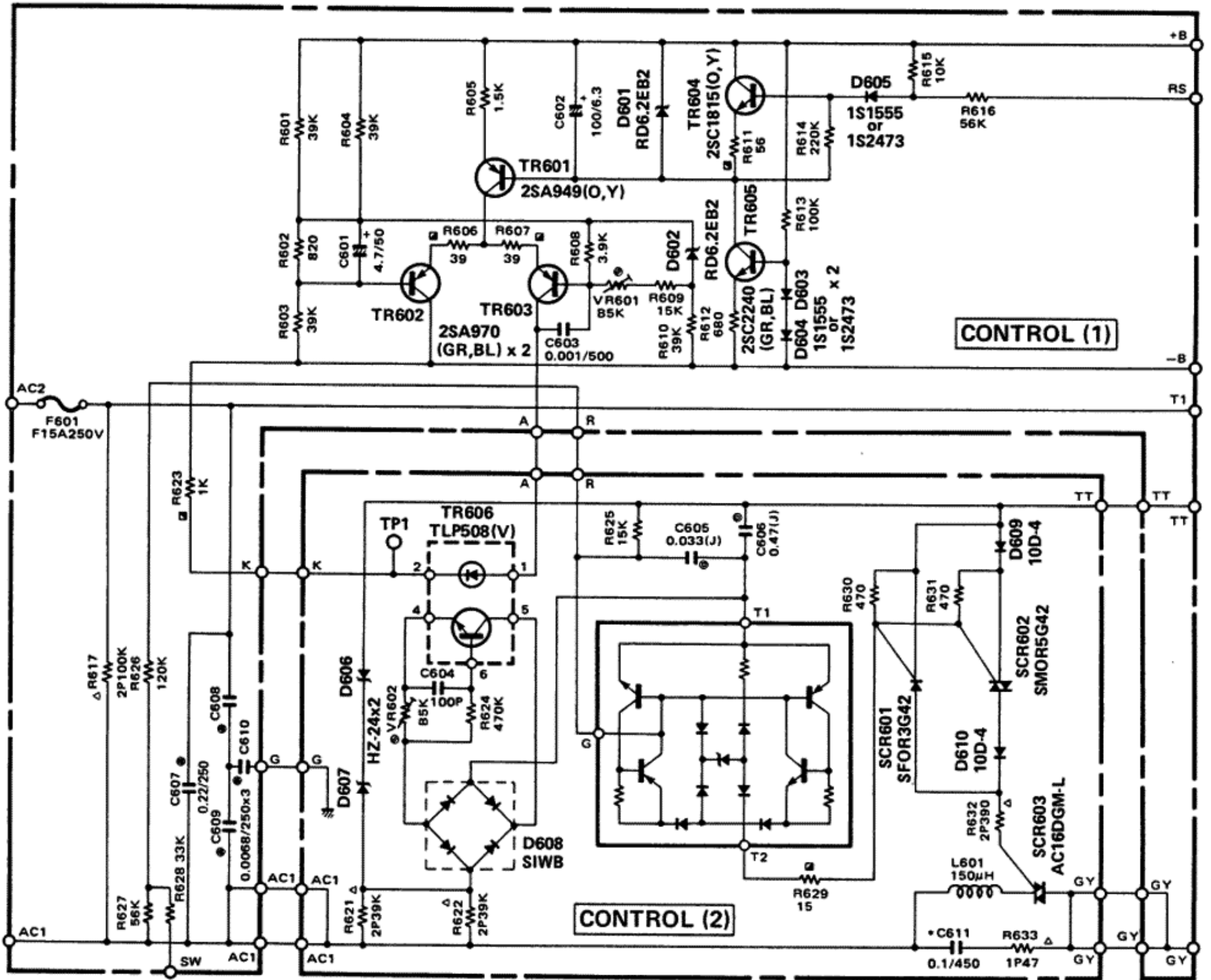

# CONTROL C. BOARD / SCHEMATIC DIAGRAM (British, Australian and European models)

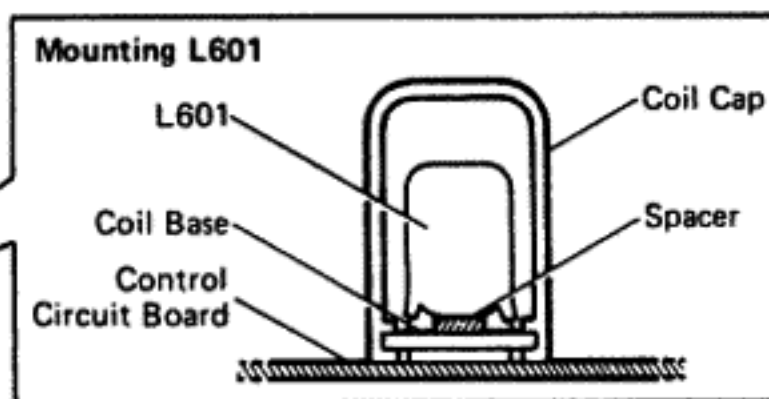
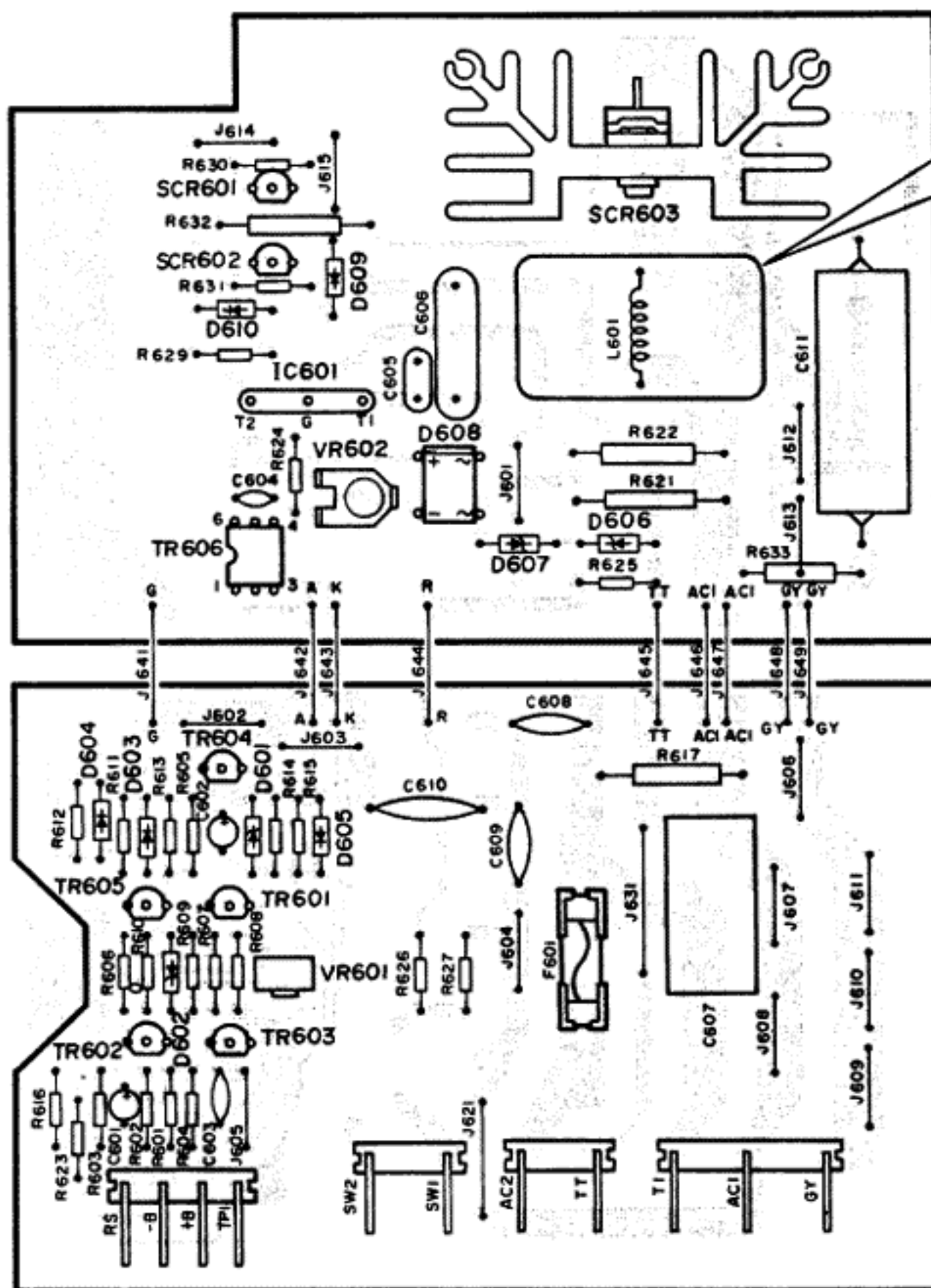
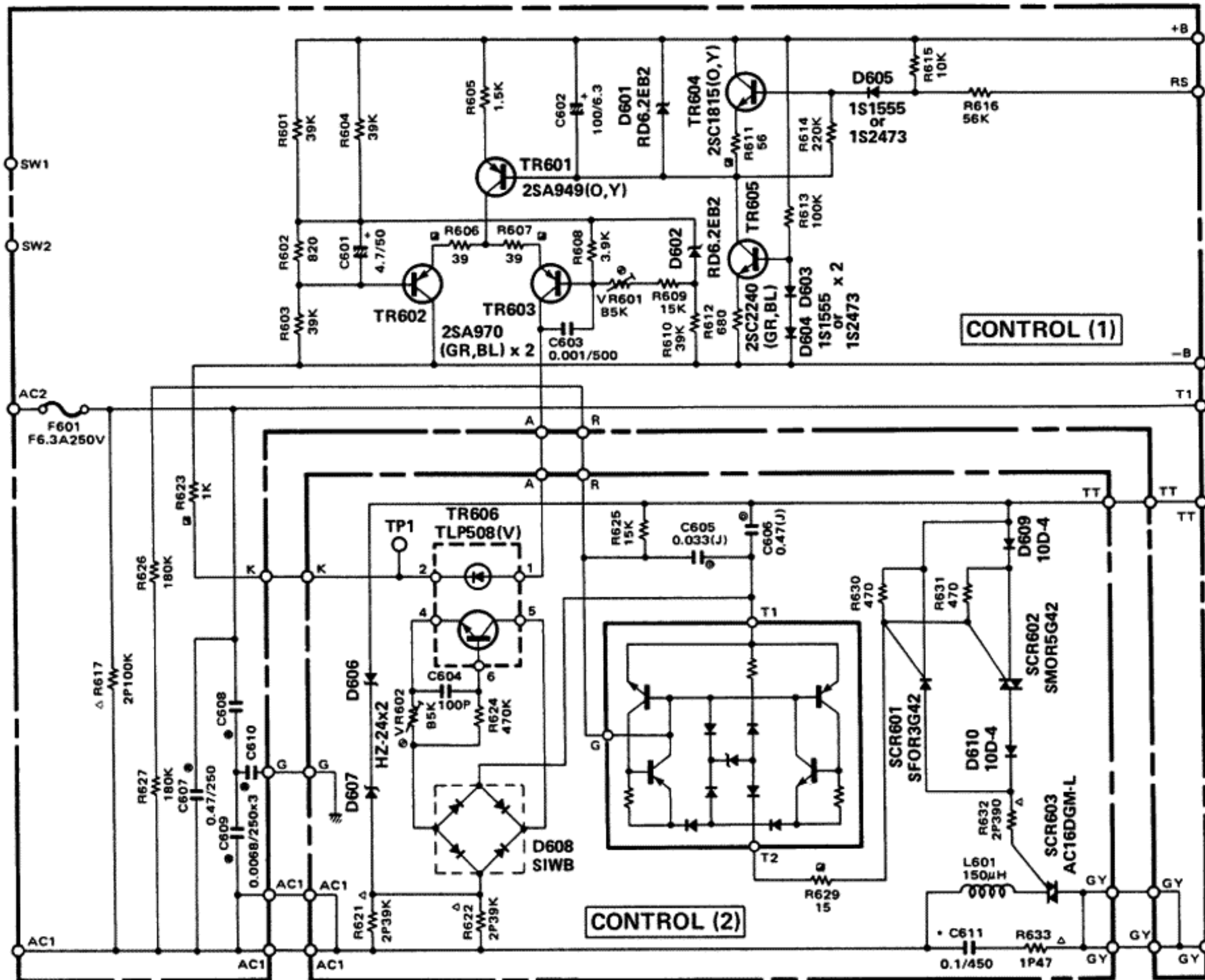

NOTE: (F), (D) models only

C602	47/6.3	UW917470
R612	1k	HJ356100
TR606	4N35	iK000350

# BLOCK DIAGRAM

